



# BOWMAC®

08/2011

## STRUCTURAL BRACKETS CATALOGUE

SUPERIOR QUALITY, HOT DIP GALVANISED, HEAVY DUTY BRACKETS FOR FIXING TIMBER TO TIMBER, TIMBER TO CONCRETE, TIMBER TO STEEL



The BOWMAC product range is designed to cut building costs. The extensive range of brackets suits all types of timber construction, and provides the designer and builder with a versatile, economic and very extensive joining system.

## DESCRIPTION

The BOWMAC product range of fixing brackets, supports and braces is specifically designed for use in all types of timber construction. All products utilise high grade steel, and rigorous quality control ensures a quality product.

## STANDARDS

Applicable timber standards are NZS 3603 and NZS 3604:2011.

## GALVANISING

All components are hot dip galvanised to AS/NZS 4680 to 600gm/m<sup>2</sup>.

## DESIGN LOADINGS

These can be derived from the allowable bolt loads in timber, using the relevant design code. Recommended loadings for pole to brace cleats B128, B145 & B155 only are shown here. Refer to separate brochure for loadings data.

## STANDARD PRODUCT RANGE

This catalogue details the standard range of BOWMAC products. Refer to separate brochure for Stainless Steel 304-2B product.

## SPECIAL PRODUCTS

BOWMAC also manufactures custom made products to suit specific requirements. A lead time, by discussion, is required to allow for manufacture.

## AVAILABILITY

The BOWMAC product range is available from leading Builders Supply Merchants throughout New Zealand.

## END USE

The purchaser is responsible for checking the suitability of any component for its intended use.

## POST AND BEARER BRACKETS

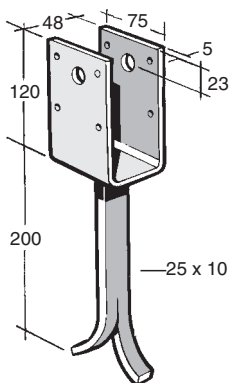

**B132**  
(Nails Included Only)

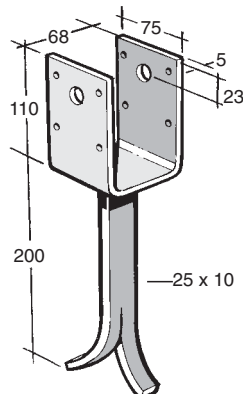

**B133**  
(Nails Included Only)

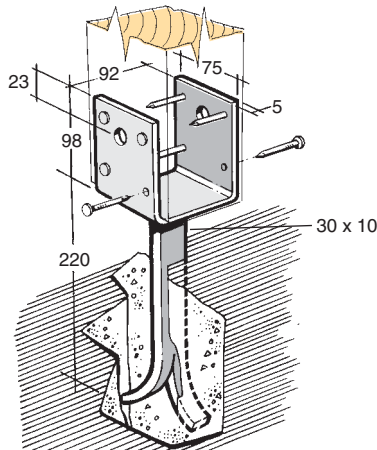

**B134**  
(Nails Included Only)

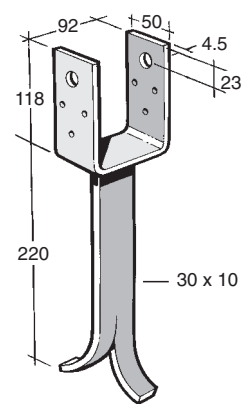

**\*B135**  
(Nails & Bolt Included)

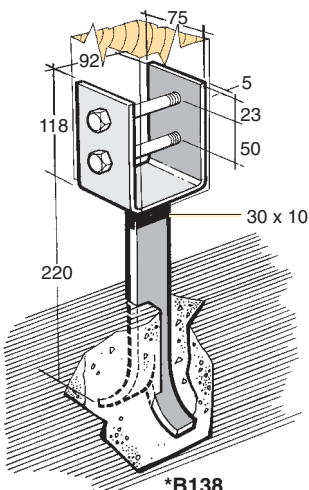

**\*B138**  
(Bolts Included)

\* Similar also available  
in stainless steel 304-2B  
Refer to brochure

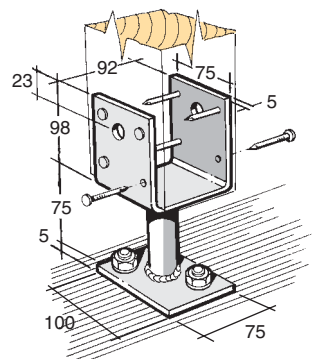

**B12**  
(Nails Included Only)

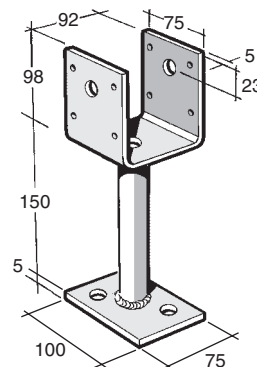

**B14**  
(Nails Included Only)

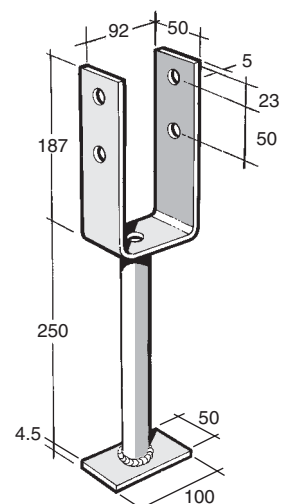

**B16**  
(Bolts Not Included)

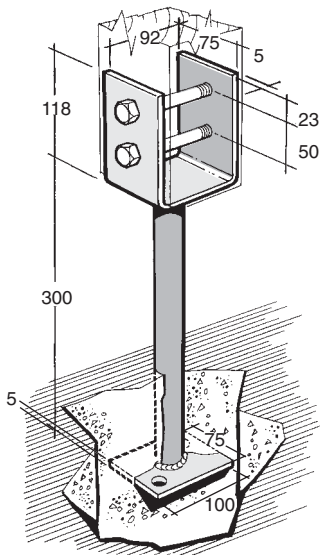

**B18**  
(Bolts Included)

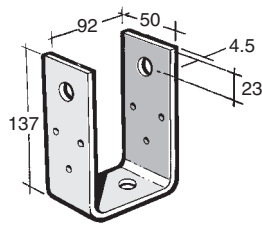

**\*B25**  
(Nail, Bolt & 2 Dyna Bolts Included)

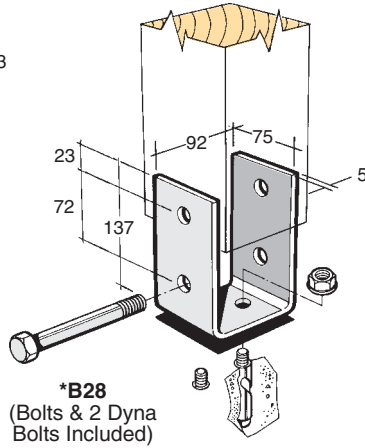

**\*B28**  
(Bolts & 2 Dyna Bolts Included)

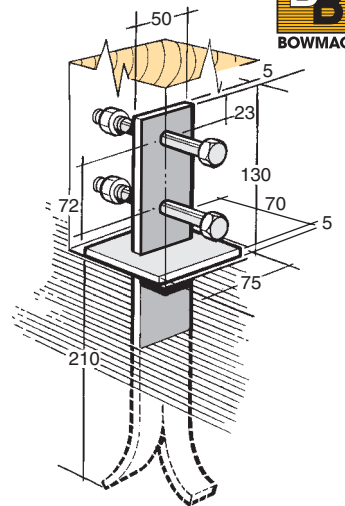

**B195**

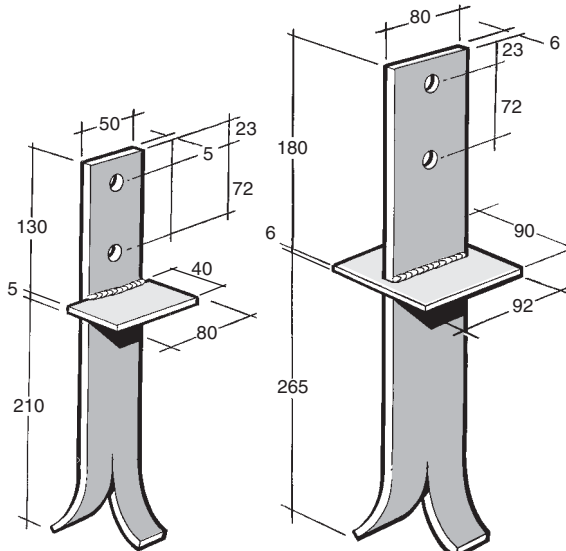

**B196**

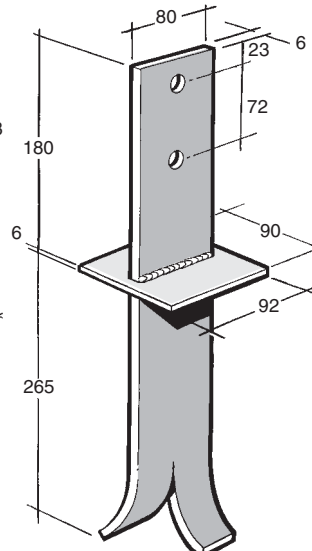

**\*B197**

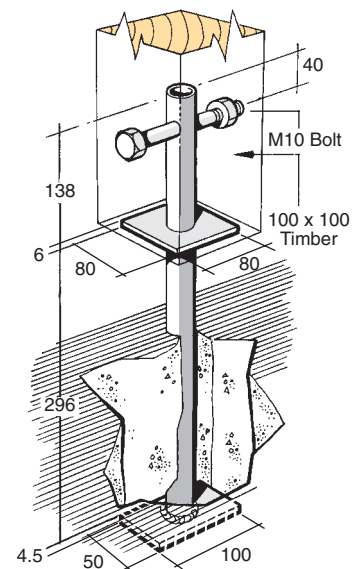

**B198**

**BOLT & NAIL SIZES**

**FIXING NOTE**

All bolt holes accommodate M12 Bolts unless noted.  
Nail holes to accommodate 40mm x 3.15Ø F. Head square twisted shank nails.  
Hot dip galvanised.

**BOLTS NOT INCLUDED UNLESS NOTED**

\* Similar also available in stainless steel 304-2B  
Refer to brochure

**STRAPS**

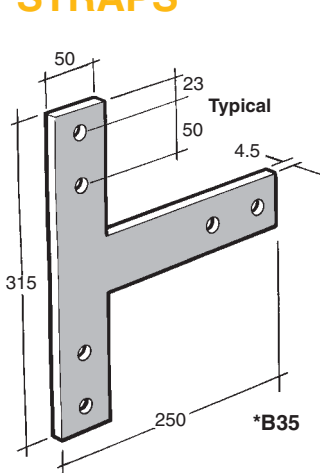

**\*B35**

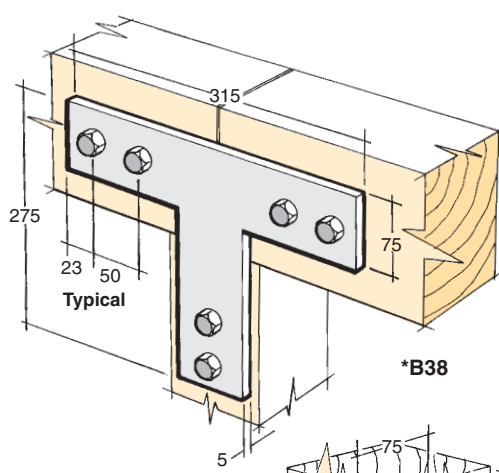

**\*B38**

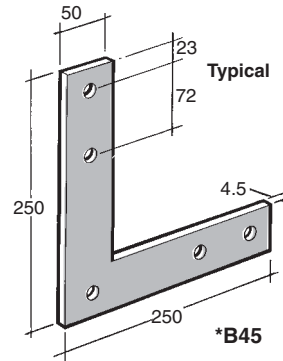

**\*B45**

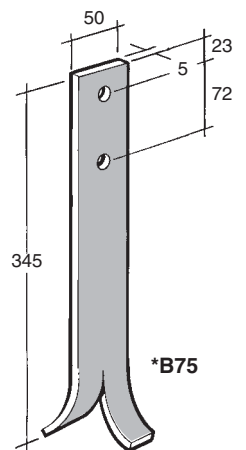

**\*B75**

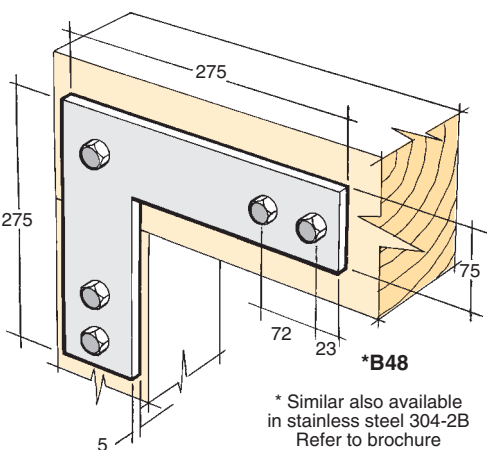

**\*B48**

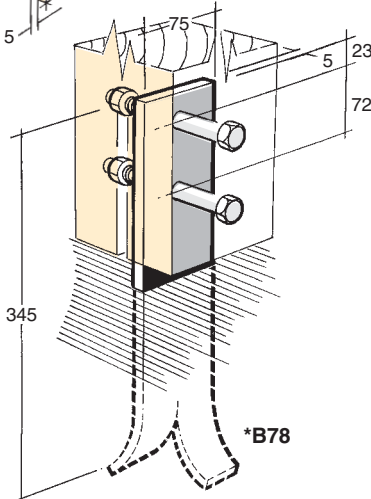

**\*B78**

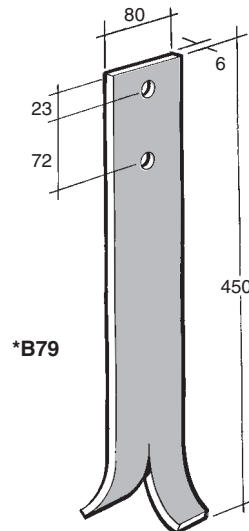

**\*B79**

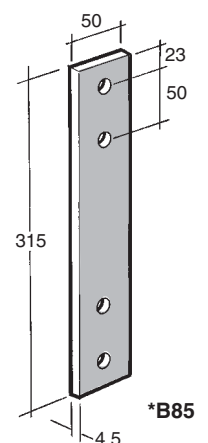

**\*B85**

\* Similar also available in stainless steel 304-2B  
Refer to brochure



### BOLT & NAIL SIZES

All bolt holes to accommodate M12 Bolts unless noted.  
 Nail holes to accommodate 40mm x 3.15Ø F. Head square twisted shank nails.  
 Hot dip galvanised.

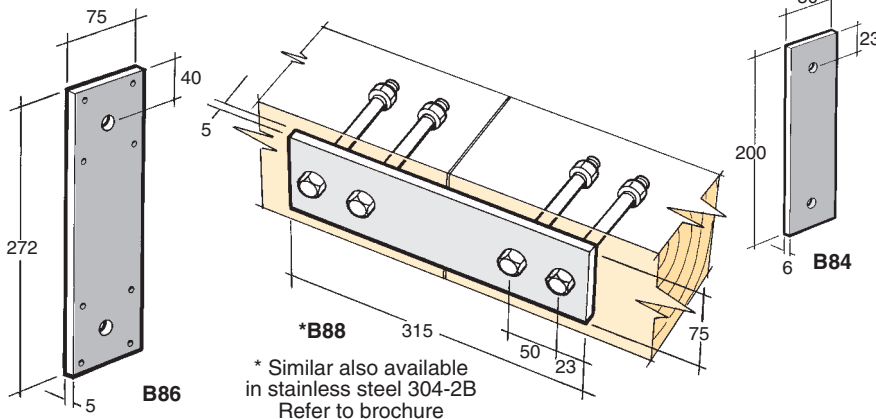

### ANGLE BRACKETS (No Gusset)

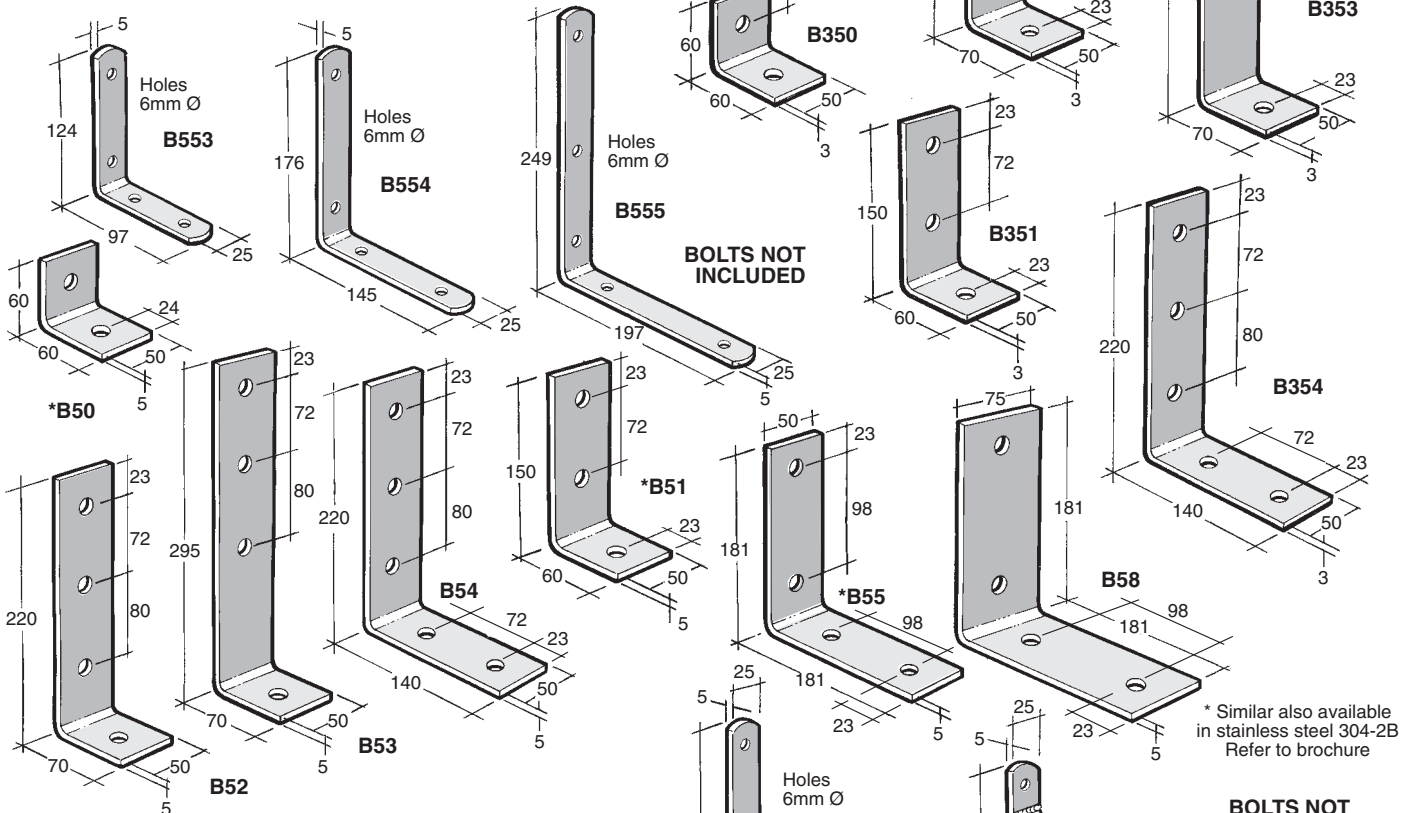

### ANGLE BRACKETS (With Gusset)

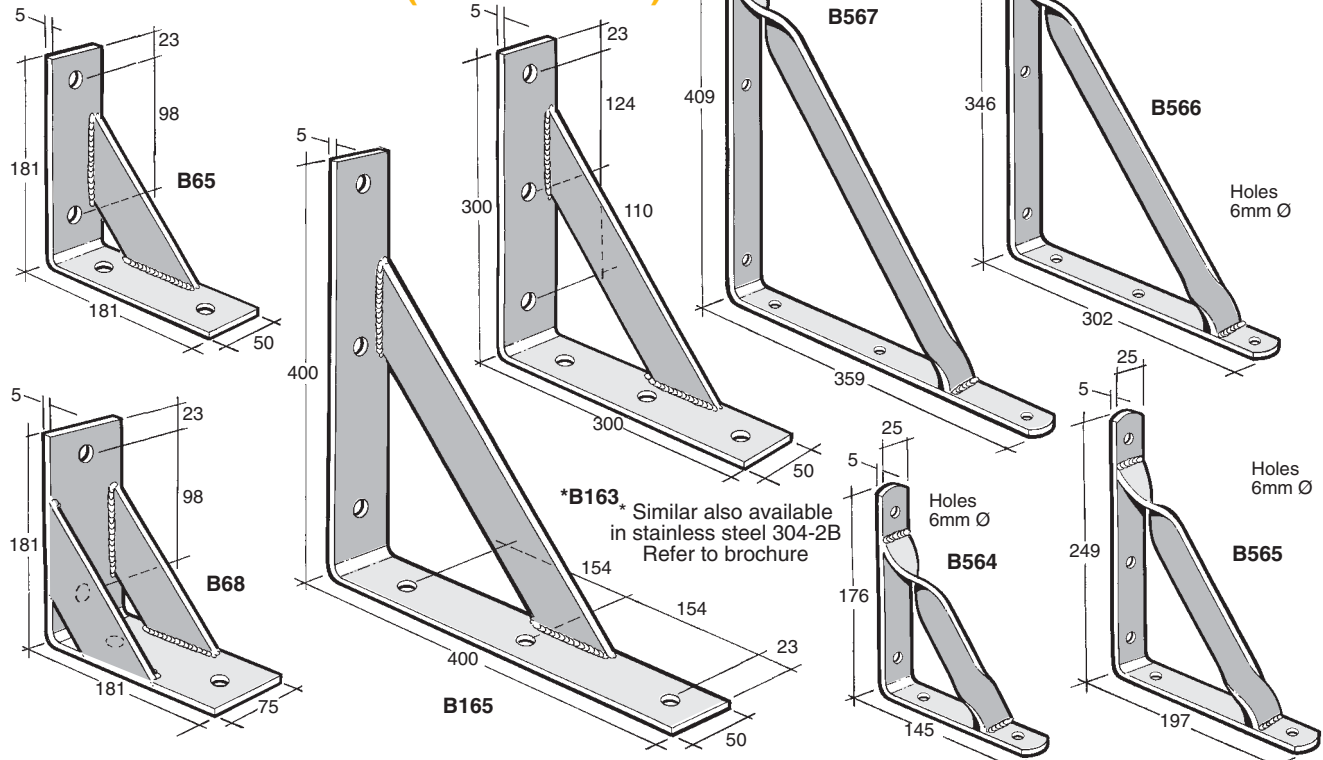

# ANGLES

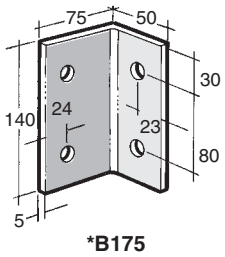

**\*B175**

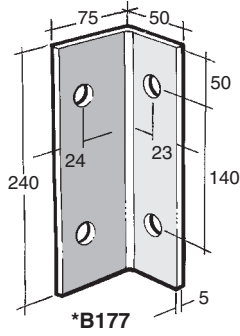

**\*B177**

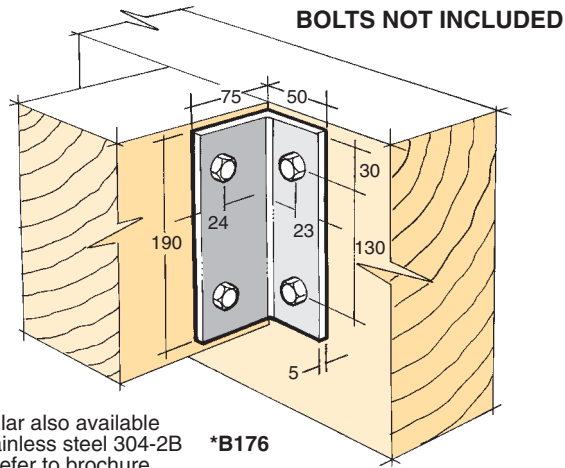

**\*B176**

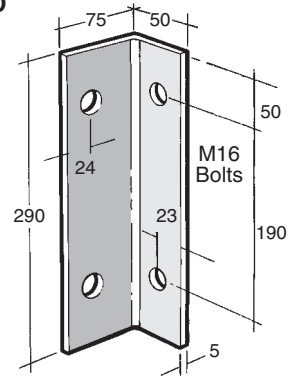

**B178**

## BOLT SIZES

All bolt holes to accommodate M12 Bolts unless noted.

\*Similar also available in stainless steel 304-2B Refer to brochure

# Z & L BEAM SUPPORTS

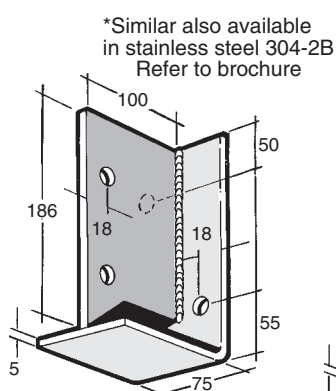

**\*B108**

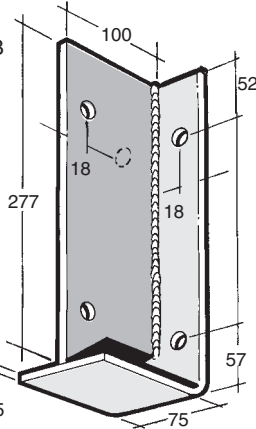

**\*B109**

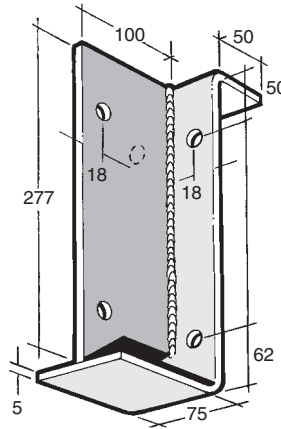

**B99**

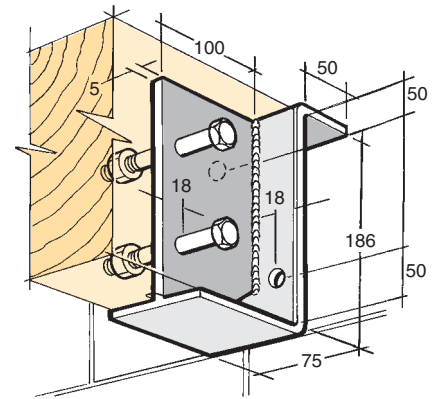

**B98**

**BOLTS NOT INCLUDED**

## \*B155 POLE BRACE BRACKET

Ex 50 x 5mm Plate 100 x 50 Channel Spacer. Supplied with 2-30mm x 16mm Ø Bolts & 2-140mm x 16mm Ø Bolts

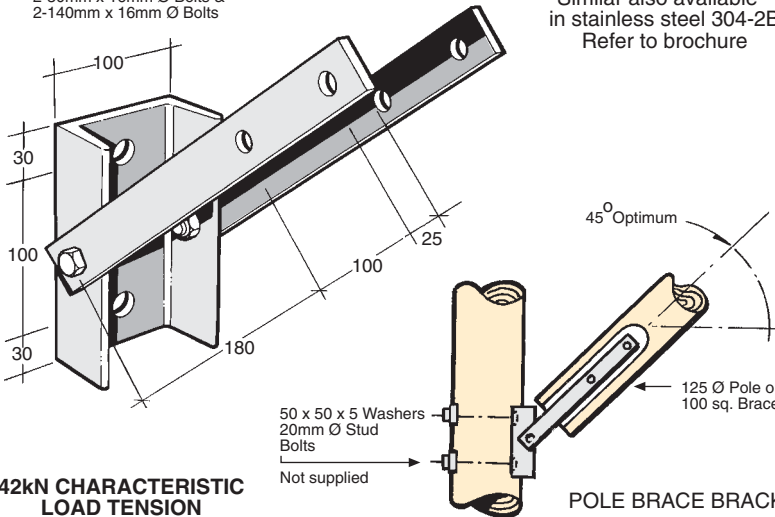

## \*B145 POLE BRACE BRACKET

\*Similar also available in stainless steel 304-2B Refer to brochure

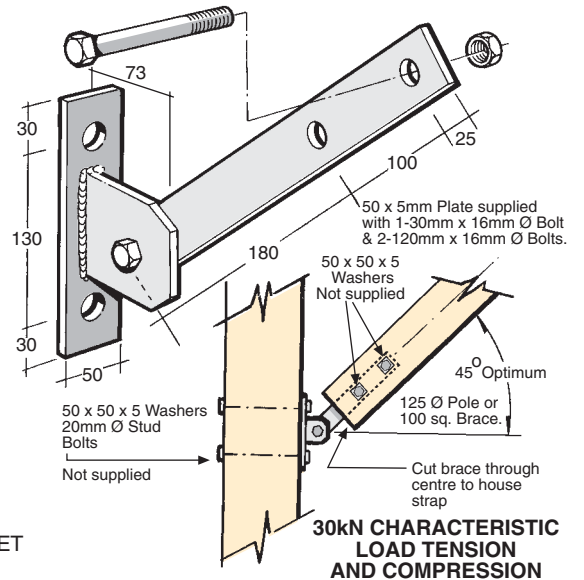

## \*B128 POLE BEAM BRACKET

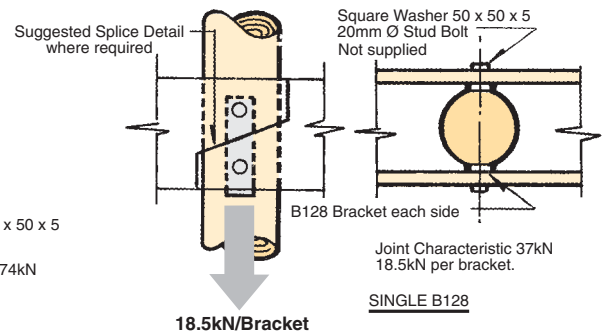
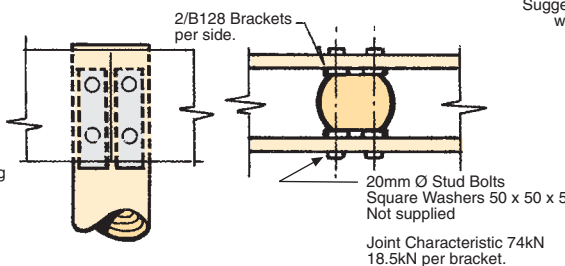
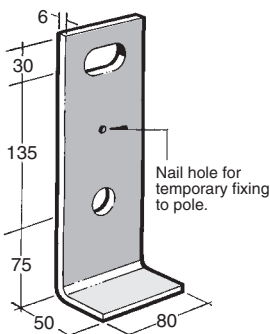

**18.5kN/Bracket**

**POLE CONSTRUCTION DETAILS (BOLTS & WASHERS NOT INCLUDED)**

### B307 SCAFFOLD BRACKET

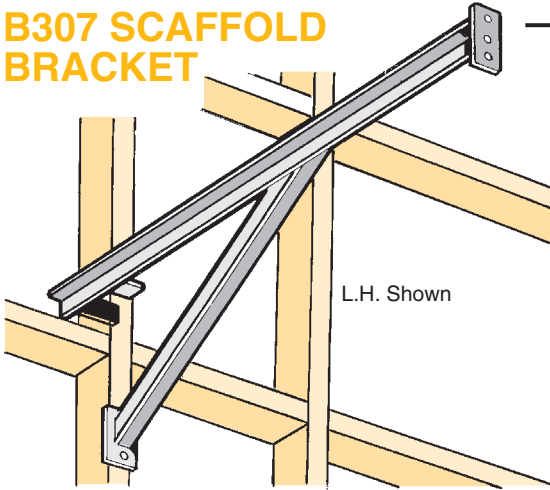

L.H. Shown

### B303 CORNER BRACKET

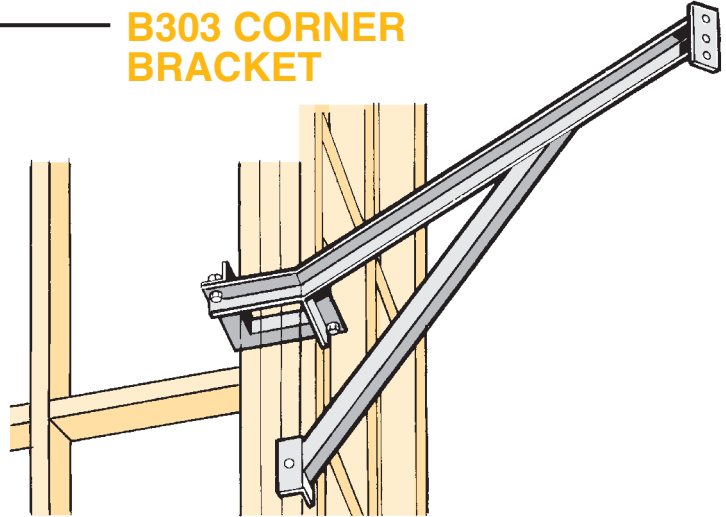

### FENCE STAY BRACKET

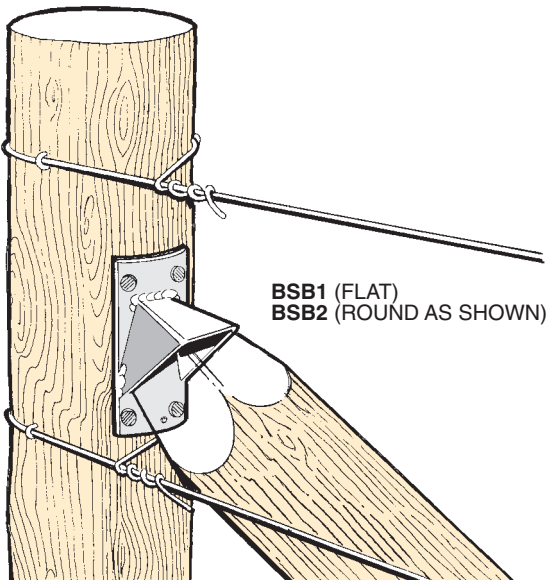

BSB1 (FLAT)  
BSB2 (ROUND AS SHOWN)

### BONZA BORER

MODEL	SIZE
BB100	100mm Dia.
BB150	150mm Dia.
BB200	200mm Dia.
BB250	250mm Dia.

