

*i*PLEX

Pipelines

SewerMAX®

- 
- ✓ High resistance to tree root intrusion and groundwater infiltration
 - ✓ Lightweight for ease of installation
 - ✓ Low embodied energy for environmental benefits
 - ✓ Long service life
 - ✓ Excellent chemical resistance
 - ✓ High pipe stiffness for deep installations
 - ✓ Cost effective

SewerMAX®

Pipes and Fittings for Gravity Sewer Mains

SewerMAX[®] is a cost-effective sewer pipe system suitable for gravity trunk sewer mains.

Manufactured from polypropylene, SewerMAX[®] pipes are highly resistant to chemical attack which can be common in sewerage and industrial wastewater pipelines. The material is also resistant in aggressive ground conditions, such as acid sulphate soils or saline ground waters.

SewerMAX[®] pipes are manufactured with a profile wall structure (smooth inner and profiled outer wall) which provides a pipe with high stiffness (SN10) for structural performance in deep trenching. SewerMAX[®] pipes are also a fraction of the weight of conventional pipe materials and can be easily manoeuvred in confined areas by hand or with light lifting equipment, making handling and installation more efficient in deep trenching.

The smooth bore of SewerMAX[®], combined with its high resistance to scale, slime and sediment build up, provides excellent hydraulic performance even in low gradient sewers.

The SewerMAX[®] rubber ring joint has been designed and tested to meet the requirements in AS/NZS 5065 which includes an 80kPa pressure and -80kPa vacuum type test.

The SewerMAX[®] joint has been designed for ease of assembly and jointing.

APPLICATIONS

SewerMAX[®] pipes and fittings are suitable for the following applications:

- Gravity sewers
- Industrial trunk sewers
- Rehabilitation of failed pipes with slip lining techniques

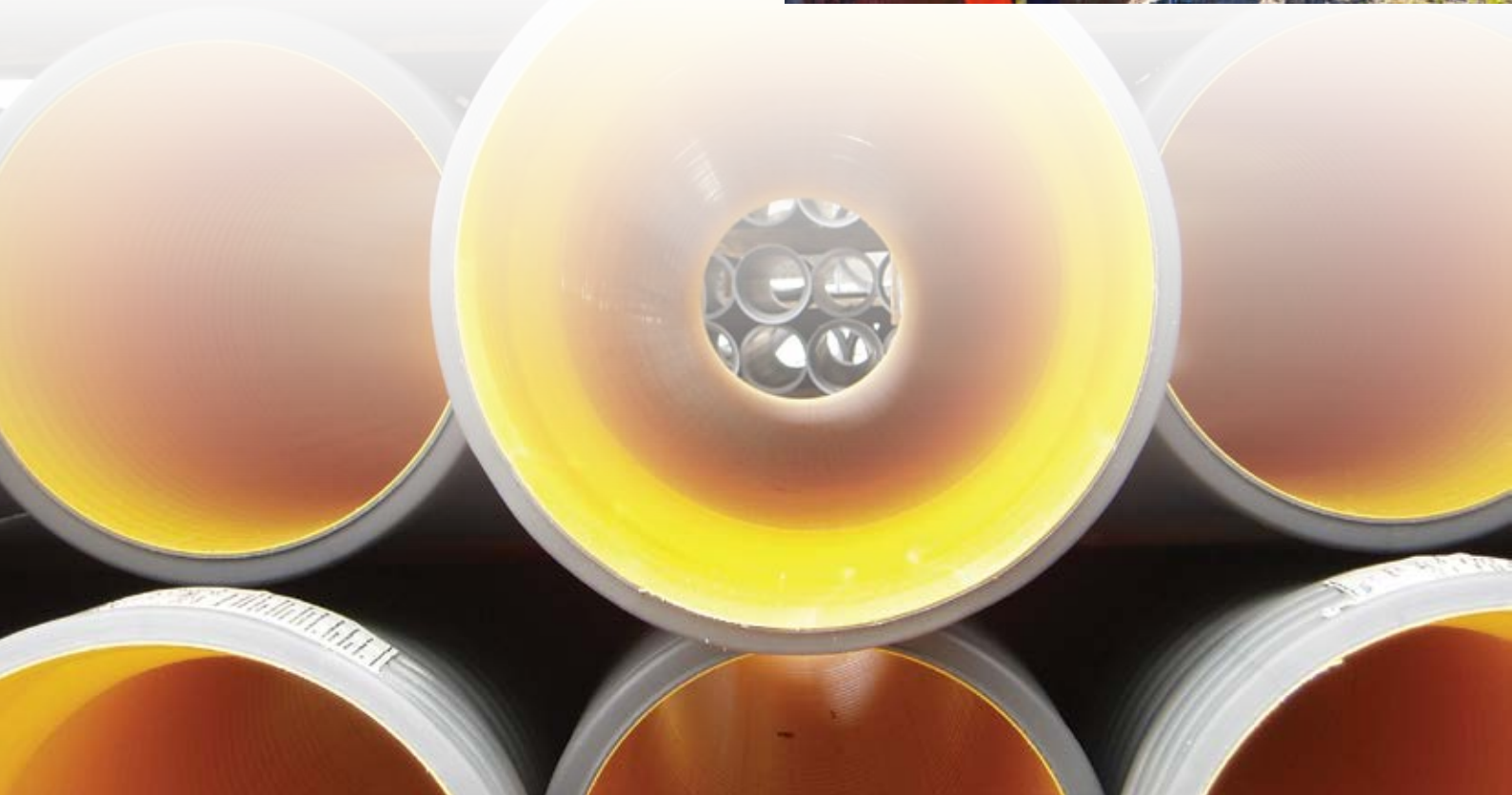

STANDARDS

SewerMAX® is manufactured to AS/NZS 5065 “Polyethylene (PE) and polypropylene (PP) pipes and fittings for drainage and sewerage applications” and has StandardsMark third party certification by SAI Global under this standard. (Licence number SMKP20603)

SewerMAX® pipes and fittings have been appraised by WSAA (Water Services Association of Australia) for performance compliance with AS/NZS 5065. For further information refer to WSAA Appraisal 03/05.

JOINTING

SewerMAX® pipes are manufactured with a high performance spigot and socket rubber ring joint system.

The elastomeric seal is placed in the second last trough from the spigot end and is compressed as the spigot enters the socket.

This system allows the installer to cut the pipe on site anywhere along the pipe barrel and make the joint.

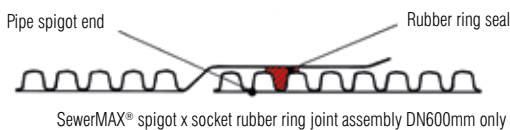
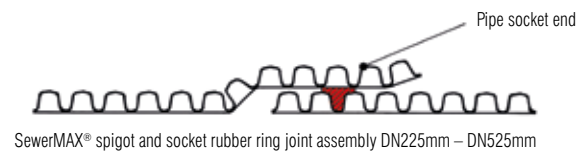

CHEMICAL RESISTANCE

SewerMAX® pipes are made from copolymer polypropylene (PP-B). The elastomeric seals used to join the pipes are made from styrene butadiene rubber (SBR).

Polypropylene is inherently resistant to a wide range of chemicals such as acids, alkalis, salts, wetting agents and alcohols.

For further information and chemical resistance charts refer to the Chemical Resistance Guide on the Iplex website www.iplex.com.au in the Design Tools section.

STRUCTURAL DESIGN

SewerMAX® pipes have a relatively high stiffness of not less than 10000 N/m.m (SN10) and are suitable for depths of up to 8 metres under normal installation conditions. The polypropylene material has a higher modulus compared with other polyolefins, such as polyethylene and combined with SewerMAX's® structured wall profile, ensures a light weight pipe with excellent long-term resistance to buckling.

For critical infrastructure projects, deep installations and where SewerMAX® is intended to be used in low strength soils, a full structural analysis should be performed.

Minimum cover heights for SewerMAX® (from AS/NZS 2566 .1 'Buried flexible pipelines Part 1: Structural design')

Location	Minimum height of cover F (m)*
Not subject to vehicular loading	0.30
Subject to vehicular loading	
– not in roadways	0.45
– in sealed roadways	0.60
– in unsealed roadways	0.75
Pipes in embankment conditions or subject to construction equipment loading	0.75

* Subject to variation by the regulatory authority.
Refer to the 'Critical dimensions for design and installation' diagrams.

For more information on the hydraulic performance and structural design of SewerMAX® please refer to the Engineering Design and Installation Guide on the Iplex website www.iplex.com.au and PIPA guideline POP015, Design Guidance for Polypropylene Structured Wall Pipes.

INSTALLATION

SewerMAX® is a flexible pipe and is therefore designed for controlled deflection under vertical soil loads. AS/NZS 2566.2 'Buried flexible pipelines – Part 2 Installation' provides detailed information on appropriate methods for the installation of SewerMAX®.

The most critical aspect for the successful installation of SewerMAX® pipes is the selection and compaction of the embedment, i.e. the material in contact with the pipe. Embedment material should be of a granular nature, which is readily compactable. Crushed rock, aggregate and graded sand are commonly used. Appendices 'G' and 'H' of AS/NZS 2566.2 provide extensive guidance on the selection and use of a wide range of embedment materials.

Critical dimensions for design and installation

DN	Dimensions				
	A (mm)	B (mm)	C (mm)	D (mm)	E (mm)
225	259	560	100	150	150
300	344	645	100	150	150
375	428	830	100	200	150
450	514	915	100	200	150
525	600	1200	150	300	150
600	682	1285	150	300	150

• Dimension 'F' refers to the table in Structural Design section 'Minimum cover heights for SewerMAX®'

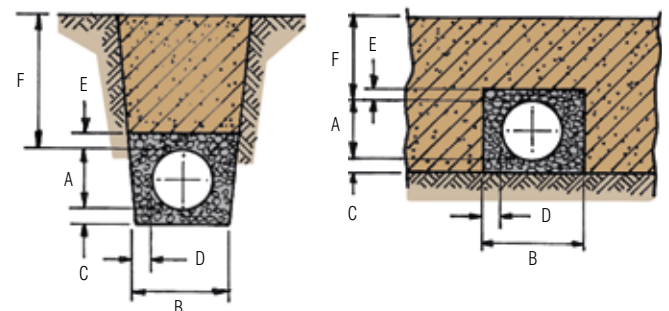

PIPE

SewerMAX® pipes are manufactured in standard 3 metre nominal lengths.

SewerMAX® Pipes

Nominal Diameter DN	Product Code	Mean Pipe OD D (mm)	Mean Pipe ID D1 (mm)	Max Overall Socket Diameter D2 (mm)	Nominal Lengths (mm)	Profile Pitch P (mm)	t1 (mm)	t2 (mm)	Approx. Pipe Mass (kg/m)
225	GR10225C	259	225	300	3005	24.9	1.4	1.7	4
300	GR10300C	344	300	400	3005	33.2	1.7	2.0	7
375	GR10375C	428	373	500	3030	39.8	2.1	2.4	11
450	GR10450C	514	447	595	3015	49.8	2.8	2.8	14
525	GR10525C	600	522	705	3005	56.9	3.2	3.2	19
600	GR10600C	682	596	725	2765	66.4	3.5	3.5	25

Note: All diameters except for DN600 are supplied with ribbed sockets.
L = Standard nominal effective lengths.

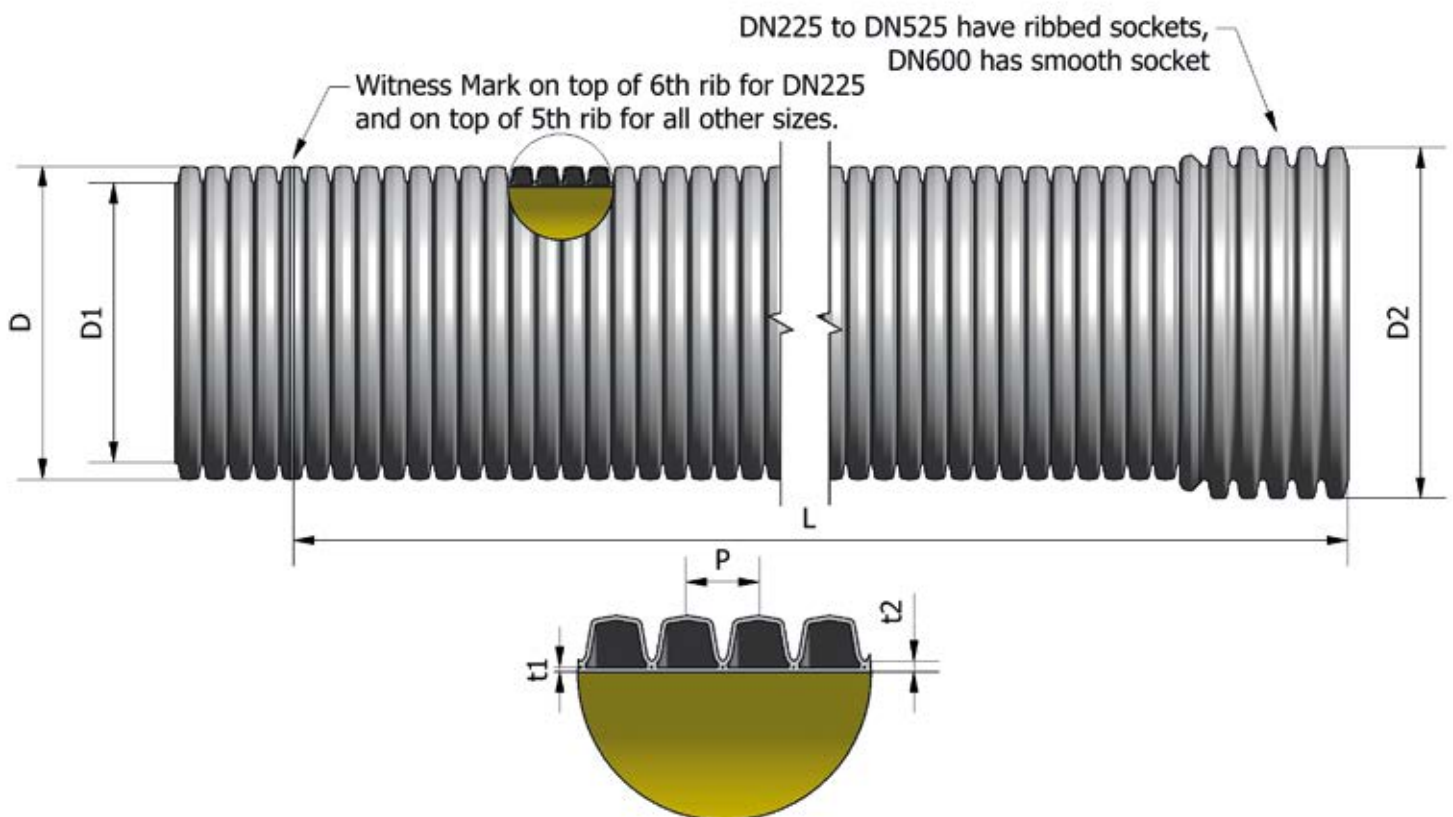

FITTINGS

A range of standard fittings in all sizes are available for use with SewerMAX® pipes providing the complete system.

GRP, GRP/PVC AND GRP/VC composite fittings are manufactured specifically for use with SewerMAX® pipes with socketed ends for connection to SewerMAX® pipe spigots. GRP fittings are also available with PVC or VC socket or spigot ends for lateral connections to incoming PVC or VC sewer pipes.

A range of stainless steel, jointing and repair clamps are available in sizes DN225–DN600 for repairs and maintenance of SewerMAX® pipes. SewerMAX® SS Junctions with reducing DN100 and DN150 DWV branch off-takes at 45° are also available, simplifying lateral side connections to property branch sewer lines without the need of cutting-in a new junction.

SewerMAX® BENDS

GRP x 45°: Socket x Socket

Product Code	Dimensions		
	DN	L (mm)	R (mm)
GFR0222545	225	191	762
GFR0230045	300	234	891
GFR0237545	375	244	1005
GFR0245045	450	291	1212
GFR0252545	525	312	1323
GFR0260045	600	329	1490

Note: • Also available in 15° & 30° Socket x Socket.

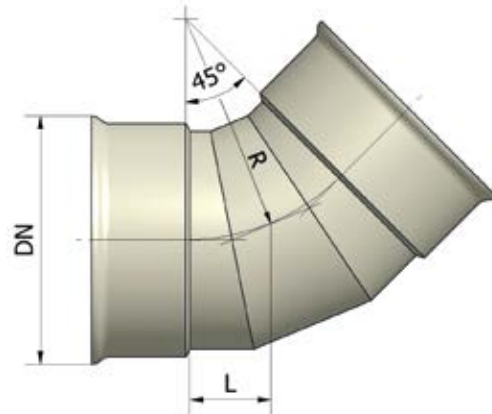

GRP x 90°: Socket x Socket

Product Code	Dimensions		
	DN	L (mm)	R (mm)
GFR0222590	225	228	370
GFR0230090	300	266	446
GFR0237590	375	302	514
GFR0245090	450	340	622
GFR0252590	525	374	699
GFR0260090	600	410	781

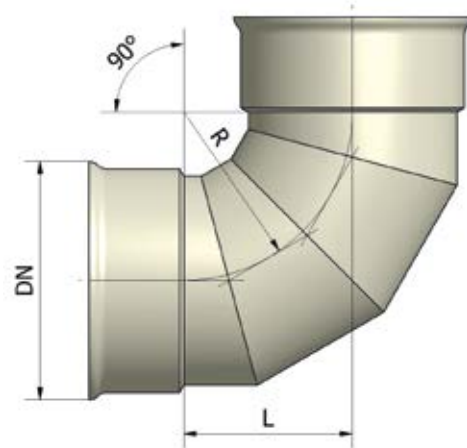

SewerMAX® EQUAL TEES

GRP x 90°: Socket x Socket x Socket

Product Code	Dimensions		
	DN	L (mm)	L1 (mm)
GFR2422590	225	325	270
GFR2430090	300	400	305
GFR2437590	375	475	313
GFR2445090	450	550	369
GFR2452590	525	625	451
GFR2460090	600	700	482

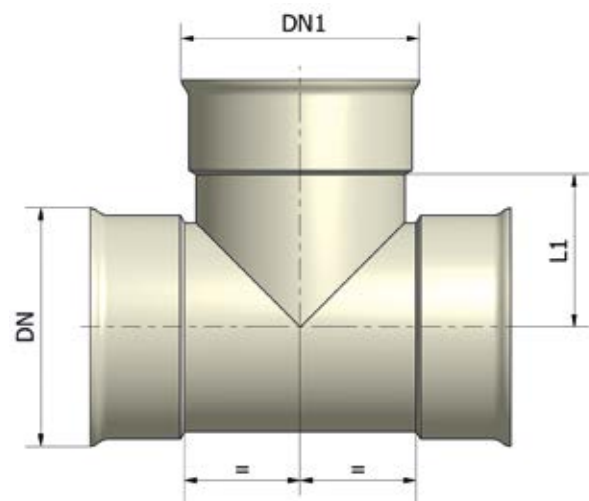

SewerMAX® REDUCING TEES

PVC x 90°: Socket x Socket x Socket

Product Code	Dimensions			
	DN	DN1	L (mm)	L1 (mm)
GFR25221090	225	100*	210	345
GFR25221590	225	150*	260	345
GFR25301090	300	100*	210	390
GFR25301590	300	150*	260	390
GFR25302290	300	225	325	315
GFR25371090	375	100*	210	345
GFR25371590	375	150*	260	390
GFR25372290	375	225	325	265
GFR25373090	375	300	400	305
GFR25451090	450	100*	210	480
GFR25451590	450	150*	260	480
GFR25452290	450	225	326	395
GFR25453090	450	300	400	358
GFR25453790	450	375	476	530
GFR25521090	525	100*	210	525
GFR25521590	525	150*	260	525
GFR25522290	525	225	326	450
GFR25523790	525	375	476	403
GFR25524590	525	450	550	411
GFR25601090	600	100*	210	620
GFR25601590	600	150*	260	620
GFR25602290	600	225	326	495
GFR25603090	600	300	400	485
GFR25603790	600	375	476	448
GFR25604590	600	450	550	459
GFR25605290	600	525	626	496

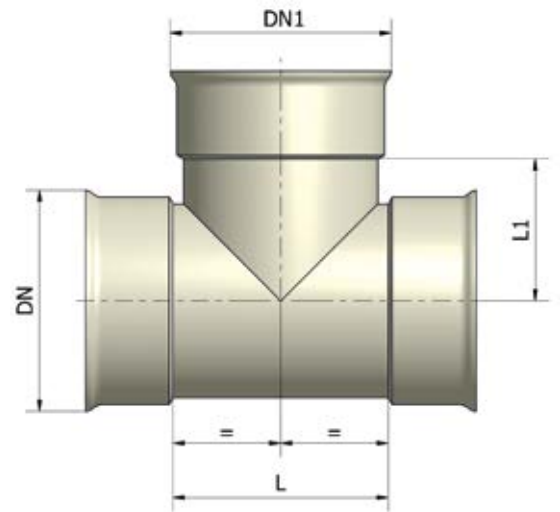

Note: * DN100 & DN150 branches are available for PVC & VC connections.
 • For DWV RRJ add 'DWV' at end of the code. *For SWJ add 'SWJ' at end of the code.
 • For VC RRJ add 'VC' at end of the code.

SewerMAX® EQUAL JUNCTIONS

GRP x 45°: Socket x Socket x Socket

Product Code	Dimensions			
	DN	L (mm)	L1 (mm)	L2 (mm)
GFR2422545	225	525	445	100
GFR2430045	300	650	573	134
GFR2437545	375	759	645	157
GFR2445045	450	913	765	175
GFR2452545	525	1034	836	187
GFR2460045	600	1165	980	200

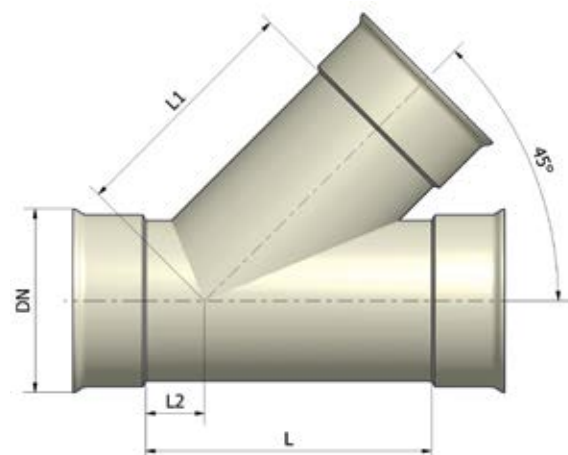

SewerMAX® REDUCING JUNCTIONS

PVC x 45°: Socket x Socket x Socket

Product Code	Dimensions				
	DN	DN1	L (mm)	L1 (mm)	L2 (mm)
GFR25221045	225	100*	366	424	25
GFR25221545	225	150*	432	424	53
GFR25301045	300	100*	398	643	25
GFR25301545	300	150*	435	643	25
GFR25302245	300	225	544	498	81
GFR25371045	375	100*	440	695	25
GFR25371545	375	150*	479	695	25
GFR25372245	375	225	524	550	25
GFR25373045	375	300	657	625	105
GFR25451045	450	100*	486	782	25
GFR25451545	450	150*	522	782	25
GFR25452245	450	225	605	603	25
GFR25453045	450	300	702	678	69
GFR25453745	450	375	805	699	120
GFR25521045	525	100*	521	803	25
GFR25521545	525	150*	558	803	25
GFR25522245	525	225	660	658	25
GFR25523745	525	375	818	753	79
GFR25524545	525	450	926	819	133
GFR25601045	600	100*	626	870	25
GFR25601545	600	150*	662	870	25
GFR25602245	600	225	711	725	25
GFR25603045	600	300	767	800	24
GFR25603745	600	375	815	820	24
GFR25604545	600	450	922	887	77
GFR25605245	600	525	1030	906	132

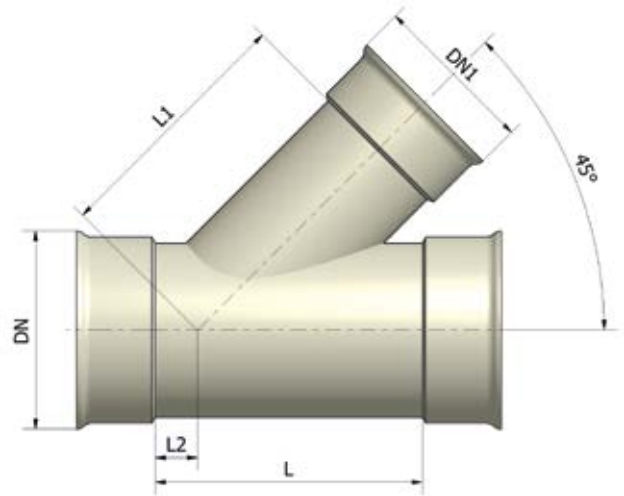

Note: * DN100 & DN150 branches are available for PVC & VC connections.
 • For DWV RRJ add 'DWV' at end of the code. • For SWJ add 'SWJ' at end of the code.
 • For VC RRJ add 'VC' at end of the code.

SewerMAX® ADAPTOR

GRP: Socket x VC Spigot

Product Code	Dimensions		
	DN	DN1	L (mm)
GFR602222VC	225	263	350

Note: • Other sizes available on request, subject to availability at time of ordering.
 • Also available in GRP: SewerMAX® Socket x VC Socket RRJ.
 GRP: SewerMAX® Socket x DWV SWJ and GRP: SewerMAX® Socket x DWV RRJ.

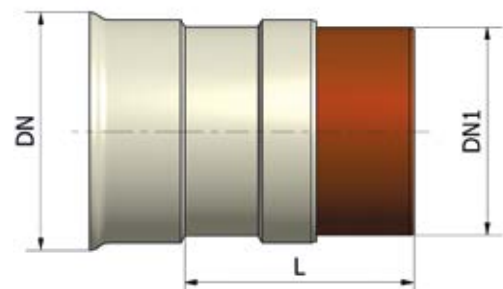

SewerMAX® STAINLESS STEEL CLAMPS

Repair Clamp

Product Code	Dimensions		
	DN	L (mm)	No. of Bolts
C37018.22530	225	300	4
C37018.30030	300	300	4
C37018.37530	375	300	4
C37018.45040	450	400	5
C37018.52540	525	400	5
C37018.60040	600	400	5

Joiner Clamp

Product Code	Dimensions		
	DN	L (mm)	No. of Bolts
C37019.22520	225	200	2
C37019.30020	300	200	2
C37019.37520	375	200	2
C37019.45030	450	300	4
C37019.52530	525	300	4
C37019.60030	600	300	4

Note: *Reducing Junction (C37017) is also available in this range.

TRANSPORTATION & STORAGE

Although SewerMAX® pipes are notably resistant to impact, they should not be rolled, dropped or allowed to come into contact with sharp objects likely to cause damage. The storage site should be level and free of obstructions.

When pipes are unloaded they should be kept in their packs until required. If pipes are not crated they should be placed on horizontal supporting timbers at approximately 2 metre centres. These timbers can also be used to separate layers when pipes are stacked individually.

Sockets should be protected from distortion during storage by ensuring all the sockets are placed at alternative ends protruding from the stack and raised clear on the ground.

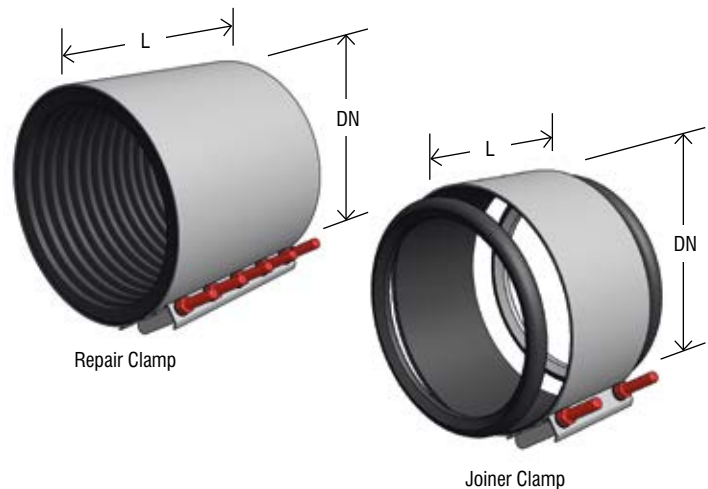

Pack Details

Nominal pipe diameter DN	Approximate pack sizes			Pipes per pack	Approximate mass of pack without timbers (kg)	Number of pipes per semi-trailer
	Width (mm)	Height (mm)	Length (mm)			
225	1090	630	3300	8	81	256
300	1090	770	3330	6	120	144
375	920 or 1340	950 or 940	3400	4 or 6	118 or 177	90
450	1080	610	3500	2	76	48
525	1890	690	3500	3	150	27
600	2130	770	3500	3	199	27

Disclaimer: The information contained in this document should serve as a guide only and is subject to change without notice. Iplex Pipelines Australia Pty Ltd does not invite any person to act or rely upon such information and liability for such information is excluded. In particular, as new technology is developed rapidly, product specifications, designs and components may change and Iplex Pipelines Australia Pty Ltd reserves the right at its discretion to make changes as it see fit. The information contained in this document does not form part of the terms and conditions of sale or constitute the description of any goods to be supplied by Iplex Pipelines Australia Pty Ltd or its distributors. Before purchasing goods, customers should source current product information from their distributor or seek expert advice on their particular intended use and application for the product. No part of this document may be reproduced, stored in a retrieval system or transmitted in any form, electronic, mechanical recording or otherwise without the prior written consent of Iplex Pipelines Australia Pty Ltd. The designs, graphics, logos, tradenames, trademarks and other intellectual property contained in this document are either owned by Iplex Pipelines Australia Pty Ltd or used with the permission of the owner or licensee, and must not be used without prior written consent. Copyright © 2013 Iplex Pipelines Australia Pty Ltd. All rights reserved. IPX/40 FEB2013

Call your Tropex Civil team to discuss specific project requirements

civil@tropex.co.nz

Ph: +649 6254 389

Tropex Civil provides for projects in the Pacific Islands and Papua New Guinea only